

SPINNING REEL **SS No.1**

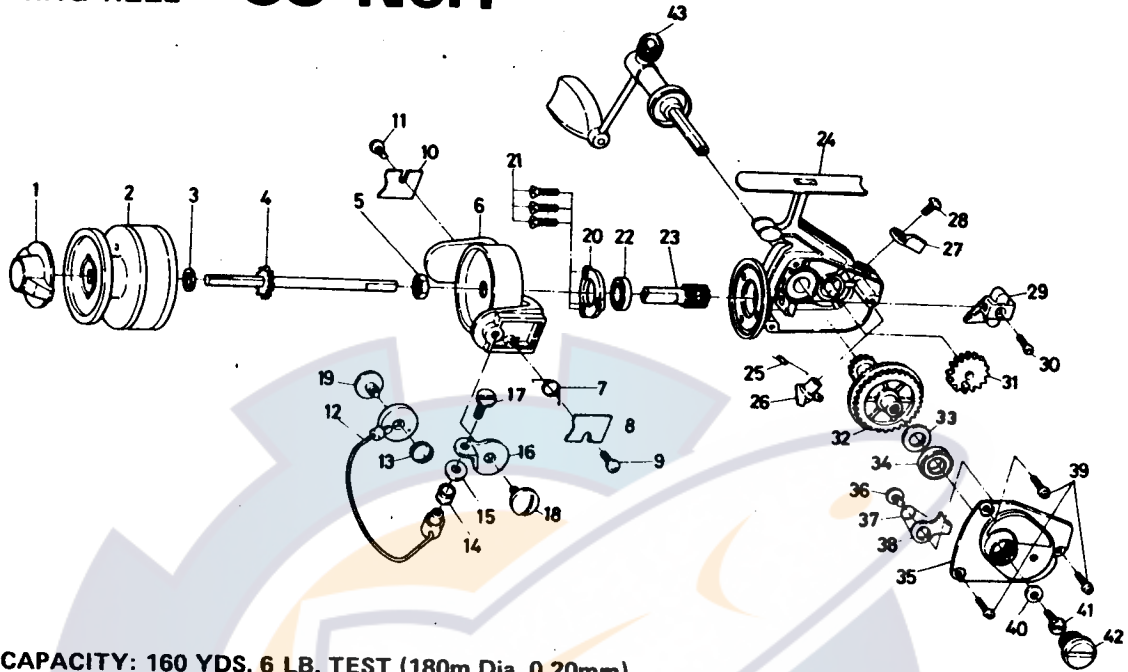

LINE CAPACITY: 160 YDS. 6 LB. TEST (180m Dia. 0.20mm)

Key No.	Parts No.	Parts Name	Key No.	Parts No.	Parts Name
1	67402301	Drag knob	23	64022201	Pinion gear
2	67310003	Spool assembly	24	67004702	Body
3	63723501	Spool washer	25	61422801	Anti-reverse cam spring
4	67107801	Main shaft	26	64606821	Anti-reverse cam
5	63419201	Rotor nut	27	65403711	Anti-reverse lever
6	67354401	Rotor	28	63501931	Anti-reverse lever screw
7	61439401	Arm lever spring	29	64810501	Oscillating slider
8	60405001	Bail spring cover	30	63510311	Oscillating slider screw
9	63511801	Cover screw	31	64130101	Oscillating gear
10	60405001	Bail spring cover	32	64130201	Drive gear
11	63511801	Cover screw	33	63705150	Drive gear washer
12	67254701	Bail	34	66341301	Ball bearing
13	61439501	Bail spring	35	67057702	Body cover
14	62503901	Line roller	36	63517701	Anti-reverse claw screw
15	65011401	Roller collar	37	61439601	Anti-reverse claw spring
16	62311501	Arm lever	38	61113401	Anti-reverse claw
17	63531801	Bail screw	39	63511001	Body cover screw
18	63632201	Arm lever screw	40	63724601	Handle washer
19	63632201	Bail holder screw	41	63621001	Handle screw
20	66341701	Bearing holder	42	63632301	Handle cover screw
21	63515311	Bearing holding screw	43	67458601	Handle
22	66341301	Ball bearing			